

PALIERES ACIER

SUIVANT NORME DK-M. 12.01
SUIVANT NORME SIDÉRURGIE 5.46.542 A

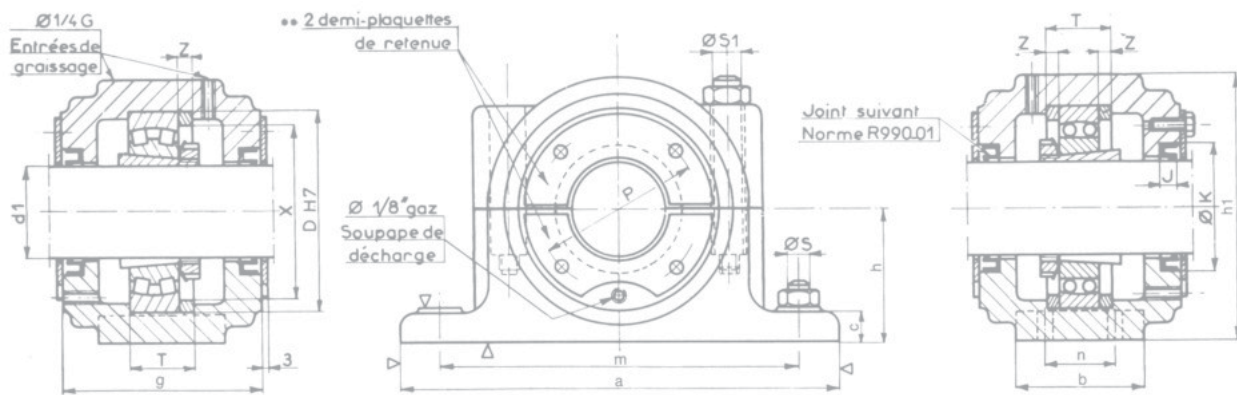

** 2 demi-plaquettes de retenue, avec vis de fixation HM6 sur ØP.
NOTA : Prévoir un jeu de 0,5 mm entre les bagues et le roulement.

d1		CORPS				SEMELLE			PERÇAGE		Ø		JOINT		BAGUE D'ARRÊT pour palier fixe				NOMBRE	ROULEMENTS	DESIGNATION MANCHONS
SERIES 1°	2°	D	g Max.	h	h1 Max.	a	b	c Min.	m	n	S	S1	T	J	ØK	P	D	X			
30	72	88	50	95	185	52	22	150	-	12	10	33	8	48	58	72	64	10	1	2207 K	H307
	35	80	91	60	110	205	60	45	170	-	12	10	33	10	52	62	80	72	10	1	2208 K
40	85	91	60	110	205	60	25	170	-	12	10	31	10	58	68	85	77	8	1	2209 K	H309
																				22209 CK	H309
																				2210 K	H310
45	90	96	60	115	205	60	25	170	-	12	10	33	12	62	72	90	82	10	1	2210 K	H310
																				22210 CK	H310
50	100	99	70	130	255	70	28	210	-	16	12	33	12	72	84	100	91	8	1	2211 K	H311
																				22211 CK	H311
60	120	114	80	150	275	80	30	230	-	16	12	43	12	80	92	120	111	12	1	2213 K	H313
																				22213 CK	H313
65	130	119	80	155	280	80	30	230	-	16	12	41	12	85	97	130	121	10	1	2215 K	H315
																				22215 CK	H315
70	140	124	95	175	315	90	32	260	-	20	16	43	12	90	102	140	130	10	1	2216 K	H316
																				22216 CK	H316
																				2218 K	H318
80	160	149	100	195	345	100	35	290	-	20	16	62.4	13	100	112	160	148	11	2	2218 K	H318
																				22218 CK	H318
																				23218 CK	H2318
90	180	160	112	215	380	110	40	320	-	22	20	70.3	13	110	122	180	166	12	2	2220 K	H320
																				22220 CK	H320
																				23220 CK	H2320
100	200	175	125	240	410	120	45	350	-	22	20	80	13	120	132	200	184	13.5	2	2222K	H322
																				22222 CK	H322
																				23222 CK	H2322
110	215	185	140	270	410	120	45	350	-	22	20	86	13	130	142	215	197	14	2	22224 CK	H3124
																				23224 CK	H2324
																				22228 CK	H3128
125	250	205	150	305	500	150	50	420	-	30	27	98	15	160	180	250	230	15	2	22228 CK	H3128
																				23228 CK	H2328
																				22232 CK	H3132
140	290	250	170	340	580	230	40	480	130	27	24	114.5	15	170	190	290	270	17	2	22232 CK	H3132
																				23232 CK	H2332
																				23136 CK	H3136
160	300	280	190	380	650	260	45	540	150	30	27	116.5	15	190	210	300	280	10	2	23140 CK	H3140
																				23144 CK	H3144
200	370	330	240	480	820	320	56	680	190	36	33	140.5	15	230	250	370	346	10	2	23148 CK	H3148
																				23152 CK	H3152
240	440	370	280	560	940	360	70	790	210	39	36	164.5	18	280	300	440	416	10	2	23156 CK	H3156
																				23152 CK	H3152

1° - Série principale
2° - Série secondaire

1. PALIERS

2. ROULEMENTS

3. EMBOUTS A ROTULES

4. PRODUITS D'ACCOMPAGNEMENTS